



Electronic
Theatre
Controls, Inc.

CONCEPT
LIGHTING CONTROL SYSTEM

DESCRIPTION

Electronic Theatre Controls, Inc.
3002 West Beltline Highway
Middleton, Wisconsin 53562
(608) 831-4116

Live Show Lighting Control
System Description
December 2, 1982

TABLE OF CONTENTS

INTRODUCTION i

PART 1.00 OPERATION 1

 1.01 GENERAL 1

 1.02 KEYPAD - GENERAL 1

 A. 0-9 KEYPAD 1

 B. + SWITCH 1

 C. - SWITCH 1

 D. . SWITCH 1

 E. CLEAR ENTRY 1

 F. ENTER 1

 1.03 CHANNEL CONTROL FUNCTIONS 1

 A. WRITE BY CUE 2

 B. WRITE BY CHANNEL 2

 C. AND 2

 D. THRU 2

 E. AT 3

 F. AT FULL 3

 G. LEVEL TOUCH BAR 3

 1.04 CUE FUNCTIONS 3

 A. SELECT CUE 3

 B. SUBROUTINE 4

 C. RISE TIME 4

 D. DECAY TIME 4

 E. CLEAR CUE 4

 F. FADE TYPE 5

 G. DUP 5

 H. SEQUENCE 5

 1.05 SUBROUTINE FUNCTIONS 6

 A. UP CURSOR 6

 B. DOWN CURSOR 6

 C. CUE SELECT 6

 D. DELAY 7

 E. LOOP 7

 F. REVERSE 8

 G. MENU 8

 H. DELETE LINE 8

1.06	DISPLAY FUNCTIONS.....	9
	A. FADER STATUS DISPLAY	9
	B. STAGE DISPLAY	9
	C. BLIND DISPLAY	9
	D. FADER DISPLAY	10
	E. MANUAL DISPLAY	10
	F. CHANNEL SCAN DISPLAY	10
	G. SOFTPATCH DISPLAY	11
	H. PRINT	12
1.07	FILE CONTROLS.....	12
	A. RECORD	12
	B. CLEAR SYSTEM	12
	C. FROM TAPE	13
	D. TO TAPE	13
1.08	GRAND MASTER	14
	A. BLACK OUT	14
	B. GRAND MASTER	14
1.09	SUBMASTERS.....	15
	A. FADER	15
	B. BUMP SWITCH	15
1.10	CROSS FADERS	15
	A. FADERS	16
	B. LOAD SWITCH	16
	C. CLEAR SWITCH	16
1.11	AUTO FADERS	16
	A. GO SWITCH	16
	B. HOLD SWITCH	16
	C. CLEAR SWITCH	17
	D. FADE OUT	17
	E. CUE OPERATING MODE	17
	1. CROSS FADE	17
	2. PLUS FADE	17
	3. MINUS FADE	18
	F. SUBROUTINE OPERATING MODE.....	18
1.12	BATTERY BACK-UP FUNCTION	18
1.13	REMOTE FOCUS UNIT	19
	A. INITIALIZATION	19
	B. KEYPAD	19
	C. CHANNEL CONTROL FUNCTIONS	19
	D. LEVEL DISPLAY	19
	E. CUE/CHANNEL DISPLAY	19
	F. GO SWITCH	19
	G. HOLD	19
	H. SELECT CUE	19
	I. PROGRESS DISPLAY	19

PART 2.00	SPECIFICATIONS	20
2.01	GENERAL	20
2.02	ARCHITECTURE	20
A.	OVERVIEW	20
B.	CONSOLE	20
C.	MAIN FRAME	20
D.	REMOTE FOCUS UNIT	20
2.03	DETAILED HARDWARE SPECIFICATIONS	20
A.	CONSOLE	20
1.	ELECTRICAL	20
2.	CONNECTORS	22
3.	MECHANICAL	23
B.	MAINFRAME	23
1.	ELECTRICAL.....	23
2.	CONNECTORS	24
3.	MECHANICAL	25
C.	REMOTE FOCUS UNIT	25
1.	ELECTRICAL.....	25
2.	CONNECTORS	26
3.	MECHANICAL	26

This document is the confidential property of Electronic Theatre Controls, Inc. and is loaned subject to return upon demand; title to this document is to be used pursuant to written license or written instructions of Electronic Theatre Controls, Inc. All rights to designs and inventions are reserved by Electronic Theatre Controls, Inc. Possession of this document is accepted subject to the foregoing conditions.

Specifications and information contained in this document are subject to change at any time.

Copyright 1982, Electronic Theatre Controls, Inc.

PART 1.00 - OPERATION

1.01 GENERAL

- A. The intent of this section is to describe the operation of the LIVE SHOW LIGHTING CONTROL SYSTEM produced by Electronic Theatre Controls, Inc.
- B. In this section, each function and control is described in technical detail as to how it will affect the system. An asterisk "*" following the function name indicates that there is an illuminated indicator associated with the switch.

1.02 KEYPAD - GENERAL

The KEYPAD is used to select numbers for CHANNEL CONTROL FUNCTIONS, CUE CONTROL FUNCTIONS, etc. There is a 4 digit seven segment display above the KEYPAD that displays the number selected. This display rolls so that the last entered digit appears in the right-most location.

- A. 0-9 KEYPAD
Ten switches that are used for numerical entry.
- B. + SWITCH
A switch that increments the number in the KEYPAD DISPLAY to the next applicable number.
- C. - SWITCH
A switch that decrements the number in the KEYPAD DISPLAY to the next applicable number.
- D. . SWITCH
A decimal point switch for entry of inserted CUES and fractional fade rates.
- E. CLEAR ENTRY
A switch that clears any numerical entry in the KEYPAD DISPLAY when depressed. This function will not remove the KEYPAD from its assignment to a control function.
- F. ENTER
This switch is used to terminate any entry of information from the KEYPAD and to verify certain actions.

1.03 CHANNEL CONTROL FUNCTIONS - GENERAL

The following control functions are used to control channels, groups of channels and CUES (in the manner of WRITING BY CUE). The modification of a channel by either the AT switch or the LEVEL TOUCH BAR will not affect the level of that channel in any recorded level information, but any change that is made will determine the output of the system until the channel(s) is released from control of the KEYPAD using the RELEASE switch (see Section 1.06.B. Stage Display).

All channels under control of the KEYPAD will be indicated on the CHANNEL DISPLAY by reverse video.

- A. WRITE BY CUE *
- This switch assigns the KEYPAD to the function of selecting a CUE for control of the LEVEL TOUCH BAR or the AT function. The following message will appear:

*** SELECT CUE TO WRITE BY ***

The number of the CUE selected by the KEYPAD will be mimicked in the display above this switch. When a CUE is selected for control in this manner, the AT function and the LEVEL TOUCH BAR will set the channels recorded in the CUE to their proportional levels.

- B. WRITE BY CHANNEL *
- This switch assigns the KEYPAD to the function of selecting channels for control by the LEVEL TOUCH BAR and the functions below. The following message will appear:

*** SELECT CHANNELS TO WRITE BY ***

The channel number (or the last channel number of a group) selected by the KEYPAD will be displayed on the display above this switch.

- C. AND *
- This switch allows additional channels that are not in numerical order to be selected for level modification.
- D. THRU *
- This switch allows groups of channels to be selected for level modification when the channels are in numerical sequence. There is no need to enter the lowest number of a group of channels first, e.g. '5 THRU 10' is the same as '10 THRU 5'.

- E. AT *
- This switch allows the level of selected channels to be entered digitally with the KEYPAD. The following message will appear:

*** ENTER INTENSITY ***

The entered level will appear in the KEYPAD DISPLAY but the change in level will not be made until the ENTER switch is depressed. When the new level is entered, it will appear in the level display above the LEVEL TOUCH BAR. All channels selected at the time will be set to the same level.

In the case of a CUE being selected, setting it to a level using the AT function will set the channels to a percentage of their recorded levels.

- F. AT FULL *
- This switch will select a level of 100% for the assigned channels. The following message will appear:

*** ENTER INTENSITY ***

The ENTER switch must be depressed to enter the information.

- G. LEVEL TOUCH BAR
- The level touch bar is a membrane touch switch that is used to manually alter the levels of channels and CUES assigned by the KEYPAD by the SELECT CHANNEL and SELECT CUE functions.

The LEVEL TOUCH BAR will set the selected channels or CUE to the level it is touched at e.g. touching the LEVEL TOUCH BAR in the middle will set the levels to 50%.

1.04 CUE FUNCTIONS - GENERAL

The following functions are used to construct and modify a CUE after it has been selected. Note that the changes made in composing and modifying a CUE are entered in the buffer only until RECORD is activated thus transferring the information to the CUE.

- A. SELECT CUE *
- This switch dedicates the KEYPAD to selecting CUES for composing and altering. The following message will appear:

***SELECT CUE NUMBER ***

CUES may be inserted between whole numbered CUES by depressing the "." (decimal point) switch on the KEYPAD and the entering of an additional number.

B. SUBROUTINE *

Depressing the SUBROUTINE switch will change a CUE from the normal format of 96 channel levels into a master CUE that controls twenty four step multi-part fades. A subroutine is displayed in a text format consisting of CUES that are already in existence. A SUBROUTINE CUE may only be written in BLIND display mode and this switch will activate the SUBROUTINE FUNCTIONS (See Section 1.05).

C. RISE TIME *

This switch allows the assigning of upfade times for the fade going into the CUE selected in the TIMED FADERS or in the case of writing into a SUBMASTER in FADER display mode, the rise time will affect the rate at which the submaster fades up when a BUMP SWITCH is depressed. The following message will appear:

*** ENTER RISE TIME ***

Rise times of .1 second to 59.9 seconds and 1:00 minutes to 59:59 minutes may be entered.

D. DECAY TIME *

This switch allows the assigning of the downfade time for channels decreasing in intensity in the TIMED FADERS or in the case of writing into a SUBMASTER, the decay time will affect the rate at which the selected SUBMASTER fades out after a BUMP SWITCH is released. The following message will appear:

*** ENTER DECAY TIME ***

The same range of decay times as rise times may be entered.

E. CLEAR CUE

This switch clears the contents of the buffer for the selected CUE. This is to "clear the slate" before writing a new CUE. The following message will appear:

*** TO DELETE CUE, PRESS "RECORD" ***

*** TO ABORT, PRESS "CLEAR ENTRY" ***

Note that the clearing of the buffer will not change the levels recorded for the CUE until RECORD is hit, thus allowing the old information to be recalled by reselecting the CUE number with the KEYPAD.

F. FADE TYPE

This switch allows the type of fade to be specified if the CUE is to be used on an AUTO FADER. The following message will appear:

*** ENTER FADE TYPE ***
(1=AUTO CROSSFADE, 2=AUTO PLUSFADE, 3=AUTO MINUSFADE, 4=MANUAL)

The appropriate number should be selected and then ENTER is depressed to complete this function.

NOTE: See Section 1.11.E. for detailed fade descriptions.

G. DUP

This function allows CUE to be duplicated as a new CUE number. The following message will appear:

*** ENTER "1" TO DUPLICATE FROM A CUE ***
*** ENTER "2" TO DUPLICATE FROM A SUBMASTER ***

The appropriate entry should be made and ENTER depressed. The following message will appear:

*** ENTER NUMBER OF CUE TO DUPLICATE FROM ***
or
*** ENTER NUMBER OF SUBMASTER TO DUPLICATE FROM ***

After the selection and ENTERING of the appropriate number, the following message will appear:

*** ENTER NUMBER OF CUE TO DUPLICATE TO ***

When the CUE number is selected and ENTER is depressed, the duplication will be complete.

H. SEQUENCE *

When the SEQUENCE switch is depressed, the CUE SHEET will appear on the STATUS DISPLAY MONITOR that shows the currently selected CUE as the NEXT CUE and the next nine CUES, including their RISE and DECAY times. This CUE SHEET will sequence to the next recorded CUE every time that a CUE is assigned to the CROSSFADER or either of the AUTO FADERS.

During the time that the system is in SEQUENCE mode, CUES can be called up for modification on stage and in BLIND mode.

NOTE: When SEQUENCE mode is terminated (by a second depression of the switch) the Cues may be selected manually for activation in a fader.

1.05 SUBROUTINE FUNCTIONS - GENERAL

The following functions are used to construct and modify a SUBROUTINE after it has been selected.

- A. UP CURSOR
This switch moves the editing cursor up through the SUBROUTINE text.
- B. DOWN CURSOR
This switch moves the editing cursor down through the SUBROUTINE text.
- C. CUE SELECT *
This allows CUES to be selected for action in a SUBROUTINE CUE. This function will create this line text:

01. ___ FADE CUE 0 TO 00% IN 00:00.0 RISE AND 00:00.0 DECAY

And the following message will appear:

*** ENTER TYPE OF FADE ***
(1 FOR CROSSFADE, 2 FOR PLUSFADE, 3 FOR MINUSFADE)

The appropriate fade is selected and ENTER is depressed. Depressing ENTER without selecting a type will default to CROSSFADE. The line of text will now read (for example):

01. CROSSFADE CUE 0 TO 00% IN 00:00.0 RISE AND 00:00.0 DECAY

And the following message will appear:

*** ENTER CUE NUMBER TO FADE ***

The appropriate CUE is selected and ENTER is depressed. The line of text will now read (for example):

01. CROSSFADE CUE 1 TO 00% IN 00:00.0 RISE AND 00:00.0 DECAY

And the following message will appear:

*** ENTER INTENSITY ***

The appropriate LEVEL is selected and ENTER is depressed. The line of text will now read (for example):

01. CROSSFADE CUE 1 TO 100% IN 00:00.0 RISE AND 00:00.0 DECAY

And the following message will appear:

*** ENTER RISE TIME ***

The appropriate RISE TIME is selected and ENTER is depressed. The line of text will now read (for example):

01. CROSSFADE CUE 1 TO 100% IN 00:10.0 RISE AND 00:00.0 DECAY

And the following message will appear:

*** ENTER DECAY TIME ***

The appropriate DECAY TIME is selected and ENTER is depressed. The line of text will now read (for example):

01. CROSSFADE CUE 1 TO 100% IN 00:10.0 RISE AND 00:20.0 DECAY

This step is now complete, and the cursor will advance to the next line for the entering of the next step.

D. DELAY *

This switch allows a delay or wait period to be inserted between the activation of CUES. The delay period will start at the beginning of the step before the DELAY step. This function will create a line of text:

02. DELAY 00:00:0

And the following message will appear:

*** ENTER DELAY TIME ***

The delay period will scroll in from the right side and depressing ENTER will complete the function.

NOTE: The final step of any SUBROUTINE CUE must be a wait that is long enough for any fades in the CUE to be completed.

E. LOOP *

When this command is entered in a SUBROUTINE text it will automatically restart the CUE at the beginning of the CUE text and indicate how many times it should repeat the sequence. This function will create a line of text:

03. LOOP TO BEGINNING 00 TIMES

And the following message will appear:

*** ENTER NUMBER OF LOOPS TO BEGINNING ***
(ENTER 0 FOR INFINITE LOOPS)

A default mode of infinite loops can be performed by not specifying the number of repeats, which appears as 00 times.

If a number of times is specified, the SUBROUTINE will execute the LOOP that many times and then pass by the LOOP command and complete the rest of the SUBROUTINE, this allows a LOOP to be entered in the middle of a SUBROUTINE CUE.

F. REVERSE *

This command, when placed in a SUBROUTINE, will reverse the order of the CUE text automatically until it reaches the beginning of the CUE and then will start the CUE in the original order. This function will create a line of text:

04. REVERSE 00 TIMES

And the following message will appear:

*** ENTER NUMBER OF REVERSES ***
(ENTER 0 FOR INFINITE REVERSES)

The number of reverses can be entered (a default mode of infinite reverses will be performed by not specifying the number of times).

If a number of times is specified, the SUBROUTINE will execute the REVERSE that many times and then pass by the REVERSE command and complete the rest of the SUBROUTINE, this allows a REVERSE to be entered in the middle of a SUBROUTINE CUE.

G. MENU *

This function is not implemented at this time.

H. DELETE LINE

This switch removes the line of text, that the cursor is on, from the selected SUBROUTINE.

1.06 DISPLAY FUNCTIONS - GENERAL

These functions dedicate the right CRT monitor to display and print information in various formats. The variable displays will occur on the right CRT and the fixed FADER STATUS DISPLAY will be on the left CRT.

A. FADER STATUS DISPLAY

This display provides information pertinent to the playback of CUES on the system. Information resembling a CUE SHEET will indicate the next ten CUES and include brief descriptions of the CUES. The level of all faders, the CUE assigned or loaded into them, and the fade progress of the TIMED FADERS will also be displayed (Figure 1).

B. STAGE DISPLAY

This mode displays the current level of the ninety-six control channels as they affect the stage. Any changes made through the operator's keyboard will be made to the levels on stage when in this mode.

Once a channel or channels are under control of the KEYPAD in STAGE DISPLAY mode, changes in the level by the AT switch or LEVEL TOUCH BAR will be reflected onstage regardless of the levels for the channel(s) caused by any fader. All channels that have been modified in the stage mode will remain "captured" by and their levels controlled by the KEYPAD until the RELEASE switch is depressed.

If another display mode is selected while the channel(s) is still under control of the KEYPAD (i.e. BLIND DISPLAY to change levels in the affected CUES) the channel(s) will remain at the set levels until STAGE DISPLAY is reselected and the channel(s) are released from control of the KEYPAD at which point they will revert to the levels caused by the faders.

RECORD will store the levels as displayed on the CRT in the CUE selected (Figure 2).

C. BLIND DISPLAY *

This mode displays the channel levels in the CUE presently selected by the KEYPAD (Figure 3).

This display mode is used for 'blind plotting' of a show. Changes made to recorded information will not affect the levels or actions on-stage. A CUE that has been altered in this manner can be stored permanently by the RECORD function.

The information will remain in the buffer until a new CUE is selected by the KEYPAD.

A CUE can be made into a SUBROUTINE in this display mode (see SUBROUTINE above) and this will cause the display to show another format (Figure 4).

D. FADER DISPLAY *

This display indicates the status and output of any fader. This switch, when depressed, will cause a message on the right CRT (Figure 5) that asks:

*** SELECT FADER NUMBER ***

(1-24 FOR SUBMASTERS, 25 FOR CROSSFADER, 26 FOR AB FADER, 27 FOR CD FADER)

The status and levels of channels under control of the selected fader will then be displayed (Figure 6).

In the case of a SUBMASTER being displayed, the levels shown will be the full recorded levels for the 96 channels. The channels may be set to different levels and recorded into the displayed SUBMASTER. The RISE and DECAY times for the bump switches may also be entered in this mode.

In the case of the CROSSFADER or TIMED FADERS being displayed, the levels indicate the current output of the displayed fader.

E. MANUAL DISPLAY *

This display indicates the levels of the ninety-six control channels as currently set by a manual lighting controller and allows those levels to be recorded as a CUE. When this display mode is entered the message appears:

*** TO READ BACK MANUAL BOARD, PRESS "ENTER" ***
(READBACK MODE WILL BLACKOUT THIS SYSTEM'S OUTPUT)

NOTE: Since there is a softpatch in this system, the system takes the first dimmer in its own softpatch for a channel and assumes the level seen as the level for the channel.

F. CHANNEL SCAN DISPLAY *

A display of one channel (the channel currently selected by the KEYPAD) in all of the recorded CUES. The level for the selected channel in each CUE will appear under the CUE number. If more CUES are recorded that can be displayed on the monitor, a second depression of the CHANNEL SCAN switch will display the next group. When the CHANNEL SCAN switch is depressed, a message will appear:

*** SELECT CHANNEL TO BE SCANNED ***

Once the levels have been displayed, they can be modified in one CUE or a group of CUES by using the KEYPAD in SELECT CUE mode and then utilizing the AND and THRU switches. The following message will appear:

***** SELECT CUES TO BE MODIFIED *****

Their levels changed with the AT function or the LEVEL TOUCH BAR. A message will appear:

***** ENTER INTENSITY *****

New levels may then be stored with the RECORD function.

NOTE: The levels for a channel can only be recorded into CUES that are already recorded. Thus selecting to modify a channel in CUES 1 THRU 100 will not create any new CUES within that block.

G. SOFTPATCH DISPLAY *

This display indicates the assignment of the two hundred twenty-four dimmers in the ninety-six channels (Figure 8). The channel number will appear followed by all of the dimmers assigned to it. Subsequent dimmers are displayed by additional depressions of the SOFTPATCH display switch.

NOTE: A dimmer may be patched to only one channel at a time: Assigning a dimmer that is already patched to another channel will remove it from the original channel.

When in this mode, the softpatch can be modified. A message will appear:

***** ENTER DIMMER NUMBERS *****

Dimmers to be patched into a channel are selected first (using the AND and THRU functions) and the ENTER is depressed. A message appears:

***** TO ASSIGN DIMMERS, SELECT CHANNEL # (1-96) THEN PRESS "ENTER" *****
***** TO DELETE DIMMERS, SELECT "0" THEN PRESS "ENTER" *****

Selecting the channel number and then depressing ENTER will store the new patch and return the point of selecting dimmer numbers.

When the system is powered up, or CLEAR SYSTEM is executed, a default softpatch will be entered. This patch has dimmers 1-96 in channels 1-96, dimmers 97-192 in channels 1-96, and dimmers 193-224 in channels 1-32.

H. PRINT *

This function will allow the contents of any display mode on the right CRT to be printed on an owner supplied printer. The system will then either print the selected display, or in the case of the BLIND display being selected, ask:

*** ENTER LAST CUE TO BE PRINTED ***

When the last CUE to be printed is selected, and ENTER is depressed the system will continue to print until the selected CUE is printed.

NOTE: Changing display modes during a PRINT will stop that print.

1.07 FILE CONTROLS - GENERAL

These functions control the memorizing, storage and playback of CUES.

A. RECORD *

This switch transfers information currently in the temporary buffer to the RAM and replaces information in the RAM with the new information. A message will appear:

*** TO RECORD, PRESS "ENTER" ***
*** TO ABORT, PRESS "CLEAR ENTRY" ***

Depressing ENTER will complete the RECORD function, thus making the change to the CUE. Depressing CLEAR ENTRY will abort the RECORD function and not make any change to the recorded information in the CUE.

B. CLEAR SYSTEM *

This switch when depressed will create the message:

*** TO CLEAR SYSTEM, PRESS "ENTER" ***
*** TO ABORT, PRESS "CLEAR ENTRY" ***

Depressing ENTER will complete the CLEAR SYSTEM function, thus erasing all of the CUE information in the system's memory and returning the softpatch to the default setting. Depressing CLEAR ENTRY will abort the CLEAR SYSTEM function and return to the previous display mode.

D. FROM TAPE *

This function will cause the system to retrieve the directory of the tape that is inserted into the the tape drive. A message will appear:

*** TO READ FROM TAPE, SELECT SHOW # (1-5) THEN PRESS "ENTER" ***
*** TO ABORT, PRESS "CLEAR ENTRY" ***

SHOW 1: RECORDED
SHOW 2: RECORDED
SHOW 3: RECORDED
SHOW 4: NOT RECORDED
SHOW 5: NOT RECORDED

A show consists of 200 CUES, a softpatch and the 24 SUBMASTER assignments. Selecting a recorded show number and depressing the ENTER switch will start the system loading a show from the tape into the working memory. A message will appear:

"FROM TAPE"
IN PROGRESS

SHOW 1: RECORDED
SHOW 2: RECORDED
SHOW 3: RECORDED
SHOW 4: NOT RECORDED
SHOW 5: NOT RECORDED

NOTE: During FROM TAPE operations, all fades in progress at the time will be halted for the duration of the tape function. The output of the system to the dimmers will be frozen at their current levels on the activation of the FROM TAPE function. The fades will continue at the completion of this function.

E. TO TAPE *

This function will cause the system to retrieve the directory of the tape that is inserted into the the tape drive. A message will appear:

*** TO RECORD ONTO TAPE, SELECT SHOW # (1-5) THEN PRESS "ENTER" ***
*** TO ABORT, PRESS "CLEAR ENTRY" ***

SHOW 1: RECORDED
SHOW 2: RECORDED
SHOW 3: RECORDED
SHOW 4: NOT RECORDED
SHOW 5: NOT RECORDED

A SHOW NUMBER is selected as the destination of the information that is contained in the console memory at

the time and ENTER is depressed to initiate the transfer of information to the tape. The levels will remain in the memory of the console, the TO TAPE function duplicates the information without erasing it from memory. When ENTER is depressed, a message appears:

**"TO TAPE"
IN PROGRESS**

SHOW 1: RECORDED
SHOW 2: RECORDED
SHOW 3: RECORDED
SHOW 4: NOT RECORDED
SHOW 5: NOT RECORDED

NOTE: During TO TAPE operations, all fades in progress at the time will be halted for the duration of the tape function. The output of the system to the dimmers will be frozen at their current levels on the activation of the TO TAPE function. The fades will continue at the completion of this function.

NOTE: "TAPE ERROR" messages will occur from the following causes:

- Tape cassette is "write protected"
- Tape cassette is not inserted in drive unit
- Tape drive unit is not functioning properly

1.08 GRAND MASTER - GENERAL

The GRAND MASTER potentiometer and BLACKOUT switch provide means to reduce or totally remove the output of the system. These actions are taken without affecting the status of the fades in the system.

A. BLACK OUT *

This alternate action switch zeros the output of the system when activated. The levels indicated in the STAGE display mode will remain at their normal intensities, but the effect of a STAGE RECORD will be to record the levels at 0%. The word BLACKOUT will appear black on a light background (reverse video) on the CHANNEL DISPLAY MONITOR as long as the BLACKOUT switch is activated.

B. GRAND MASTER

This potentiometer allows the output of the system to be reduced or completely zeroed. The level of the GRAND MASTER is displayed on the CHANNEL DISPLAY MONITOR. Any time that the level of the GRAND MASTER is below 100%, the level is indicated in reverse video.

1.09 SUBMASTERS - GENERAL

The SUBMASTERS are a set of 24 manual faders which pile on to each other individually as well as to all the other faders in the system. Any of the 96 control channels may be assigned to any of the SUBMASTERS. The levels of the channels can be proportional, with the recorded levels affected by the level of the SUBMASTER. The contents of a SUBMASTER may be displayed and recorded in FADER DISPLAY MODE (see Section 1.06.D.)

The RISE and DECAY times that are associated with the BUMP switches are displayed and recorded in FADER DISPLAY MODE.

The level of the submaster, whether set by the potentiometer or the BUMP switch, is displayed on the STATUS DISPLAY MONITOR under the SUBMASTER number.

- A. FADER (24 EACH NUMBERED 1-24)
A linear slide potentiometer to set the level of the SUBMASTER.
 - B. BUMP SWITCH (24 EACH NUMBERED 1-24) *
- A momentary switch which will bring the assigned contents of the SUBMASTER to full intensity. When the BUMP switch is depressed its level will start to rise to full at the recorded rate. Assuming that the BUMP switch is held longer than the recorded RISE time, the level will reach full and decay in the recorded DECAY time when the switch is released. If the BUMP switch is released prior to the CUE reaching full intensity, the CUE will decay from that point at the recorded DECAY rate. If no rates are recorded, the bump action will be instantaneous.

The BUMP switch has an LED indicator which lights when the SUBMASTER has any levels recorded into it.

1.10 CROSS FADERS - GENERAL

The CROSS FADERS are configured as separate pile on faders that allow split, dipless fades to be performed. Different CUES may be assigned to the X and the Y faders. A fade between these CUES may be performed in which levels staying the same or increasing in intensity will not show a "dip" in their levels.

The current position of the CROSS FADERS as well as the CUE assignments are indicated on the STATUS DISPLAY MONITOR.

A. FADER

Each CROSS FADER has a linear slide potentiometer to adjust the level of the CUE loaded into the fader. The two faders are reversed such that when the X fader is at a level of 100%, the Y fader is at a level of 0%. This allows the CROSS FADERS to be used to simply fade between CUES. The output of the CROSS FADERS piles on to the outputs of the other faders of the system.

Since each CROSS FADER has a separate potentiometer, lead lag fades may be performed.

B. LOAD SWITCH *

A switch that loads the selected CUE into the fader. If the system is in SEQUENCE mode, the NEXT CUE indicated in the CUE SHEET will be assigned to the fader.

C. CLEAR SWITCH

A switch that clears the fader of the CUE loaded into it.

1.11 AUTO FADERS - GENERAL

The AUTO FADERS are arranged in two pairs. These two pairs are "last action" faders, meaning that a channel will always go to the last level that is given for it. The final output of the AUTO FADERS piles on to the other faders in the system.

There are two modes of operation for the AUTO FADERS. The first controls fades for normal CUES and the second controls fades for SUBROUTINES.

A. GO *

When depressed, this switch will load the NEXT CUE into the AUTO FADER pair. The fade times will be set as recorded and the recorded CUE will be initiated in the AUTO FADER.

B. HOLD *

Depressing the HOLD switch when a fade is active in an AUTO FADER will freeze any fades which are in progress at the time, at their current levels.

The CUES will still be loaded into the AUTO FADER and the fades can be resumed by depressing the GO switch; the fades will continue from the point that they were held.

The fades can be left at the point that they were held by depressing the HOLD button a second time, in this case the levels that the fades were producing will remain as the output of the fader. Another CUE can be initiated at this point in the AUTO FADER.

C. CLEAR *

This switch will clear the fader pair of any CUE or CUES that are loaded into it. All of the output from the AUTO FADER will be cancelled.

D. FADE OUT

This function will initiate a fade to zero for all channels in the AUTO FADER. When this fade is complete, the AUTO FADER will be cleared of any CUES and the CLEAR switch will be illuminated. The fade time for the fade is the same as the DECAY time for the last CUE initiated in the AUTO FADER.

E. CUE OPERATING MODE

When a simple CUE (containing only channel level information and fade times) is initiated on an AUTO FADER pair with the GO switch, the left bargraph in the pair will indicate the progress of the up-fade portion of the fade, the TOUCH BAR acts as a manual override for this portion of the fade. Depressing the TOUCH BAR below the indicated fade progress on the bargraph will hold the fade at the level that it has reached and the fade can then be advanced manually. The progress of this part of the fade will follow the position of the override on the touch bar.

The right bargraph and touch bar perform the same function for the down-fade portion of the fade. This feature allows both the up-fade and the down-fade progress to be modified independently.

There are three types of fades that can be performed by the AUTO FADERS using simple level only CUES. These are determined by the information recorded in the CUE that is entered using the FADE TYPE function (see Section 1.04.F.). The fades will cause the following results in the AUTO FADER when a CUE is initiated.

1. CROSS FADE

All channel levels currently produced by these AUTO FADERS will be replaced by the levels recorded in the NEXT CUE.

2. PLUS FADE

Only channels with new non-zero levels in the NEXT CUE will change in intensity. All other levels produced by the AUTO FADERS will remain the same. Using this type of fade, it is possible to do infinite "fade within fade" CUES, initiating different CUES with different starting and ending times in an AUTO FADER.

3. MINUS FADE

Initiating a MINUS FADE in an AUTO FADER will take any channels that are recorded at levels greater than 0 in the CUE and fade them to 0% in the AUTO FADER.

F. SUBROUTINE OPERATING MODE

When a SUBROUTINE CUE is initiated on an AUTO FADER pair, The controls and displays will be automatically configured in a mode to allow the control of the level and rates of the fades in the SUBROUTINE.

The left-hand TOUCH BAR and BARGRAPH will act as a master level control for the SUBROUTINE. When a SUBROUTINE CUE is initiated, the level will be set automatically at 100% and can be modified at any time during the course of the SUBROUTINE.

The right-hand TOUCH BAR and BARGRAPH act as the rate control device for the SUBROUTINE. When the SUBROUTINE is initiated, The bargraph will be set in the middle of its range, indicating that the fades are running at the normal rates. By depressing the TOUCH BAR, the rates can be doubled, set to instantaneous, cut in half and halted. Modification of the rate will change both the fade times and any delay times that are recorded in the SUBROUTINE that is running in the AUTO FADER.

The STATUS DISPLAY MONITOR will indicate the step that the SUBROUTINE is executing as well as the rate and level that the AUTO FADER is set to.

1.12 BATTERY BACK-UP FUNCTION

A. DESCRIPTION

The Console contains a battery back-up power supply which will keep the system fully functional for a period of 5 minutes. The Back-up system will automatically activate when a failure of the AC input to the system is detected, or in the case of failure of the primary power supply circuit.

One minute after the power failure is detected, the system will automatically activate the TO TAPE function (see Section 1.07.D.). The show that is contained in the console will be recorded in the last show location on the tape that was loaded from.

After this function is complete, the system will remain fully operational for a total of five minutes and then shut itself down.

The batteries will recharge when AC power is restored to the Console.

1.13 REMOTE FOCUS UNIT - GENERAL

The Remote Focus Unit (RFU) will execute certain functions of the system from distances up to 4000' from the console.

- A. REMOTE FOCUS UNIT INITIALIZATION
When the RFU is connected to the system , the OPERATOR PANEL of the console will become inoperable. Certain functions provided by this portion of the console will be duplicated by the REMOTE FOCUS UNIT.
- B. KEYPAD
See PART 1.02.A. thru G.
- C. CHANNEL CONTROL FUNCTIONS
See PART 1.03.A thru F.
- D. LEVEL DISPLAY
A two digit seven segment display to indicate the level of the selected channel or group of channels.
- E. CUE/CHANNEL DISPLAY
A four digit seven segment display to indicate the selected CUE or channel. The display functions the same as the KEYPAD DISPLAY.
- F. GO
This switch will allow any recorded CUES to be initiated on the AB AUTO FADER.
- G. HOLD
This switch will perform the same function as the AB AUTO FADER HOLD switch.
- H. SELECT CUE
This switch allows the selection of a CUE to be initiated in a fade by the GO function.
See PART 1.03.B.
- I. PROGRESS DISPLAY
Two two-digit seven segment displays to indicate the progress of a fade.

PART 2.00 - TECHNICAL SPECIFICATIONS

2.01 DESCRIPTION

- A. The intent of this Section is to describe the technical specifications, both electrical and mechanical, for the LIVE SHOW LIGHTING CONTROL SYSTEM designed and produced by Electronic Theatre Controls, Inc.

2.02 ARCHITECTURE - GENERAL

A. OVERVIEW

The system consists of three separate assemblies:

- Console
- Main Frame
- Remote Focus Unit

Each assembly has its own processor and communications between the assemblies is EIA RS-422 standard serial transmission (Ref. Drawing LSLC-001).

B. CONSOLE

The main processor for the system is contained within the Console and is responsible for fade calculations as well as the other control functions described in Part 2.00 of this document. This processor transmits the levels for 224 dimmer outputs to the Main Frame. The maximum distance between the Console and the Main Frame is 4000'.

C. MAIN FRAME

The processor in the Main Frame controls the digital to analog conversions as well as the analog to digital conversions required to 'read back' the levels from manual control board. There is also an un-programmed RS-422 interface in the Main Frame.

D. REMOTE FOCUS UNIT

The Processor in the Remote Focus Unit also communicates to the Console processor and decodes and transmits operator commands from a remote location. There is an interface connection for the Remote Focus Unit on the Main Frame the maximum distance between the Unit and the Console of 4000'.

2.03 DETAILED HARDWARE SPECIFICATIONS

A. CONSOLE

1. Electrical

a. Processor

The processor is an 8-bit Z-80 CPU on a STD bus card (Mostek MDX-CPU2-4).

- EPROM program storage

- b. RAM
128K dynamic ram on a modified Mostek MDX-DRAM16 STD bus card
- c. EPROM / Memory managment
The system has 48K of EPROM operating program storage on a STD bus card (ETC LSLC-086)
-Bank switching logic for memory managment
- d. RS-422 Serial Interfaces
Two dual port RS-422 serial interface cards (Mostek MDX-422N).
-RS-422 synchronous interface to the Main Frame at a transmission rate of 57.6 to 76.8 KBaud.
-RS-422 asynchronous interface to an Owner Provided Printer
-RS-422 asynchronous interface to the DEC TU58 tape drive at a transmission rate of 19.2 KBaud.
-RS-422 asynchronous interface to the face panel processor
- e. CRT Controllers
Two STD bus monochrome CRT controller cards (Matrox STD-ALPHA)
-RS-170 Video output
-80 characters X 24 lines
- f. DEC TU-58AB Tape Drive
Cassette tape storage unit
-System will load contents of RAM onto tape after one (1) minute power failure.
-One DECTAPE II data cartridge will be supplied with each system (DEC P/N TU58-K)
- h. Operator Keyboard
Main operator interface for setting and recalling cues and interface to cue playback functions.

-Z80 processor
-EPROM program storage
-RS-422 asynchronous interface to console processor
-86 discrete membrane switches
-73 discrete LED indicators
-3 four digit LED displays, 1 three digit LED display
-Four 51 contact membrane touch switch
-27 linear Potentiometers

- j. Power Supplies
Primary AD to DC power supplies with battery back-up providing full system operation for 5 minutes.
 - +5VDC @ 20A Primary supply
 - +12VDC @ 8A Primary supply
 - +5VDC @ 8A back-up supply
 - +12VDC @ 3A back-up supply

- k. AC Power Requirements and Circuit Protection
15 A input circuit breaker
 - 120 VAC @ 15 A max.
 - 15 A push to reset circuit breaker
(Potter & Brumfield P/N W58XB1A4A-15)

2. Connectors

- a. Main Frame Interface
Panel mounted receptacle
 - Amp Circular Plastic Connector Series 1 reverse sex square flanged receptacle 14 contacts with 12 used
(Amp P/N 206043-1)
 - Solder tab gold-plated socket contacts
(Amp P/N 202237-1)
Mating connector (for cable)
 - Amp Circular Plastic Connector Series 1 reverse sex plug
(Amp P/N 206044-1)
 - Solder tab gold-plated pin contacts
(Amp P/N 202236-1)
 - Standard Cable Clamp
(Amp P/N 206070-1)

- b. CRT Interfaces
Two UHF type coaxial connectors for CRT outputs.
 - SO-239 Panel mount receptacle
(Amphenol P/N 83-1R)
Mating connector for cabling.
 - SO-239 plug for RG/59U cable
(Amphenol P/N 83-59SP)

- c. Printer Interface
Panel mount socket connector
 - 9 contact "D" type socket connector
(TB Ansley P/N 609-9S)

- d. AC Input
Line cord with grounded straight bladed connector
 - 6'6" 14 AWG 3 wire type SJT with molded NEMA 5-15P plug
(Belden P/N 17616C)

- e. AC outputs for CRTs
Two grounded staight blade receptacles
-(Circle F P/N 1538.9)

3. Mechanical

- a. Card Cage
Ten slot STD bus card cage
-Terminated bus (Mostek P/N MDCC-10)
- b. Operator Panel
The membrane switch panel with slide potentiometers (Ref. Drawing LSLC-025)
 - 86 switches
 - 5 membrane touch bar switches
 - 27 slide potentiometers
 - Solenoid produced tactile feedback on switch closure
- c. Enclosure
A Console enclosure to provide protection to all circuitry and components.
 - 31.50" width
 - 22.00" depth
 - 6.50" height

B. MAIN FRAME

1. Electrical

- a. Processor
The processor is an 8-bit Z-80 CPU on a STD bus card (Mostek MDX-CPU2-4).
 - EPROM program storage
 - RAM
- b. Serial Interfaces
One dual port RS-422 serial interface card (Mostek MDX-422N).
 - RS-422 synchronous interface to the Console at a transmission rate of 57.6 to 76.8 KBaud.
 - RS-422 un-programmed port.
- c. Dimmer Output
Analog control circuitry for 224 dimmers.
 - 32 dimmers per STD card (ETC IO-03).
 - 0-24 VDC @ 5 MA. per output.
- d. Analog Input
Analog input from a 224 channel manual controller.
 - 32 dimmers per card (ETC IO-03).
 - 0-10 VDC input.

- d. Power Supply
 - Optional Redundant DC power supplies
 - +5VDC 20A switching supply
 - +12VDC 10A switching supply
- e. AC Power Requirements and Circuit Protection
 - 120 VAC @ 15 A 60 Hz
 - 220 VAC @ 7.5 50 Hz optional

2. Connectors

a. Console Interface

Panel mounted receptacle

- Amp Circular Plastic Connector Series 1 reverse sex square flanged receptacle 14 contacts with 12 used (Amp P/N 206043-1)
- Solder tab gold-plated socket contacts (Amp P/N 202237-1)

Mating connector (for cable)

- Amp Circular Plastic Connector Series 1 reverse sex plug (Amp P/N 206044-1)
- Solder tab gold-plated pin contacts (Amp P/N 202236-1)
- Standard Cable Clamp (Amp P/N 206070-1)

b. Remote Focus Unit Interface

Panel mounted receptacle

- 6* -Amp Circular Plastic Connector Series 1 standard sex square flanged receptacle 9 contacts with 6 used. (Amp P/N 206486-1)

- 6* -Solder tab gold-plated pin contacts (Amp P/N 66570-3)

Mating connector (for cable)

- Amp Circular Plastic Connector Series 1 standard sex plug (Amp P/N 206485-1)

- 6* -Solder tab gold-plated socket contacts (Amp P/N 66569)

- 10* -Flexible Cable Boot (Amp P/N 207489-1) and; Internal Cable Clamp (Amp P/N 207490-1)

c. Dimmer Control Interface

Panel mount socket connector (7 connectors)

- 37 contact "D" type mass terminated connector (TB Ansley P/N 609-37S)

Mating Connector (for cabling)

- 37 pin "D" type plug (TRW)

- d. Manual Controller Interface
 - Panel mount socket connector (7 connectors)
 - 37 contact "D" type mass terminated connector (TB Ansley P/N 609-37S)
 - Mating Connector (for cabling)
 - 37 pin "D" type plug (TRW)
- e. AC Power Input
 - Line cord with grounded straight bladed connector
 - 6'6" 16 AWG 3 wire type SJT with molded NEMA 5-15P plug (Belden P/N 17614C)

3. Mechanical

- a. Card Cage
 - 16 Slot STD bus card cage
 - Terminated bus (Mostek MDCC-16)
- b. Enclosure
 - Rack mountable enclosure
 - 19" max width
 - 7" vertical panel height
 - 20" max depth
 - Fan cooled
 - Connectors on back of enclosure
 - Card cage accessed from front

C. REMOTE FOCUS UNIT

1. Electrical

- a. Processor
 - 8-bit processor to decode switches, drive displays
- b. Serial Interface
 - RS-422 asynchronous serial interface to console at a transmission rate of 300 to 19.2 Kbaud
- c. Power Requirements
 - DC Power supplied over control cable from either the Main Frame

2. Connector

- a. Main Frame interface cable
 - 25' interface cable
 - 3 twisted pair 24 AWG overall shield cable (Belden P/N 9503)

Connector (for cable)

- Amp Circular Plastic Connector Series
2A standard sex plug
(Amp P/N 206485-1)
- Solder tab gold-plated socket contacts
(Amp P/N 66569)
- Flexible Cable Boot
(Amp P/N 207489-1) and;
Internal Cable Clamp
(Amp P/N 207490-1)

Panel mounted receptacle

- Amp Circular Plastic Connector Series
2A standard sex square flanged
receptacle 9 contacts with 6 used.
(Amp P/N 206486-1)
- Solder tab gold-plated pin contacts
(Amp P/N 66570-3)

b. Extention Cable (typical)

Connector: Remote Focus Unit end

- Amp Circular Plastic Connector Series
2A standard sex free hanging receptacle
9 contacts with 6 used.
(Amp P/N 206486-2)
- Solder tab gold-plated pin contacts
(Amp P/N 66570-3)

Cable

- 3 twisted pair 24 AWG overall shield
cable (Belden P/N 9503)

Connector: Console end

- Amp Circular Plastic Connector Series
2A standard sex plug
(Amp P/N 206485-1)
- Solder tab gold-plated socket contacts
(Amp P/N 66569)
- Flexible Cable Boot
(Amp P/N 207489-1) and;
Internal Cable Clamp
(Amp P/N 207490-1)

3. Mechanical

a. Keypad

The keypad is a membrane switch surface (Ref. Drawing LSLC-077)

- 25 switch inputs
- 8 discreet LED indicators
- One 4 digit LCD display
- Two 2 digit LCD displays

b. Enclosure

The inclosure is aluminum with a twenty foot interface cable.

- 3.75" width
- 7.25" length
- 2.00" heigth

8 7 6 5 4 3 1

DWG NO	SH	REV	1
REVISIONS			
ZONE	REV	DESCRIPTION	DATE APPROVED

THIS DRAWING IS THE PROPERTY OF ETC, INC. IT IS TO BE USED ONLY FOR THE PROJECT AND THE USER. IT IS NOT TO BE REPRODUCED, COPIED, OR TRANSMITTED IN ANY FORM OR BY ANY MEANS, ELECTRONIC OR MECHANICAL, INCLUDING PHOTOCOPYING, RECORDING, OR BY ANY INFORMATION STORAGE AND RETRIEVAL SYSTEM. WITHOUT THE WRITTEN PERMISSION OF ETC, INC.

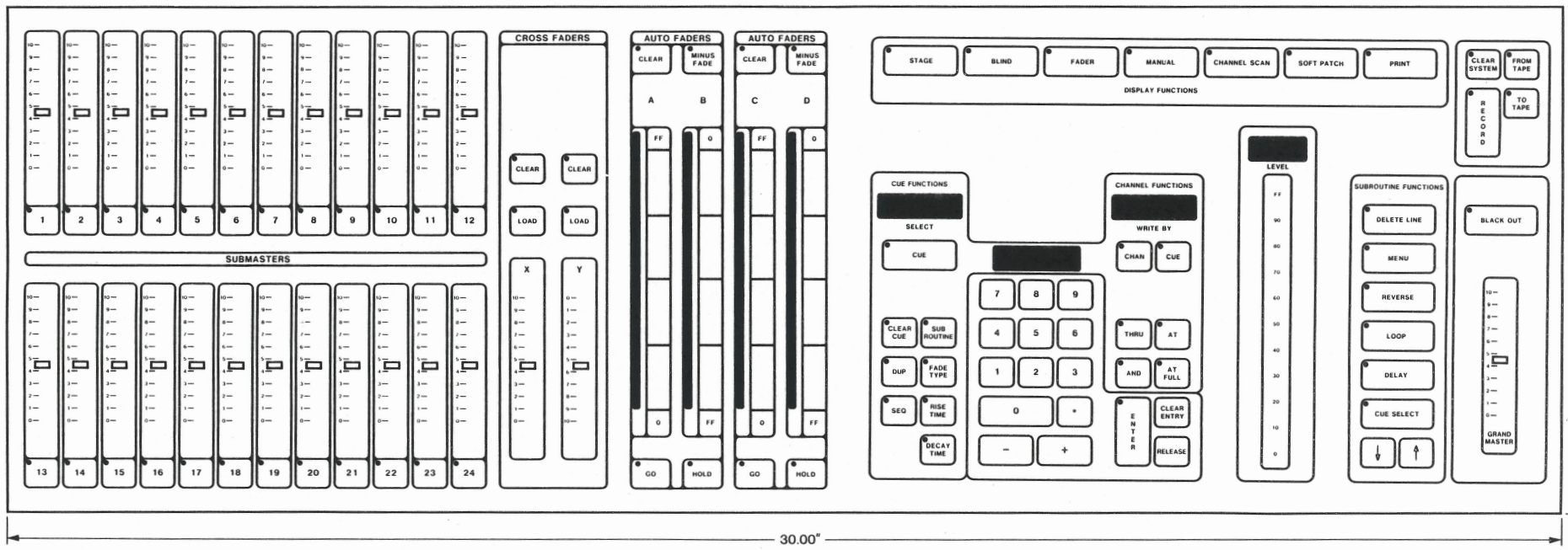

30.00" 9.75"

QTY	FSCH	PART OR	NOMENCLATURE	MATERIAL
REQD	NO	IDENTIFYING NO	OR DESCRIPTION	SPECIFICATION
PARTS LIST				
UNLESS OTHERWISE SPECIFIED DIMENSIONS ARE IN INCHES TOLERANCES ARE FRACTIONS DECIMALS ANGLES XXX		CONTRACT NO		
MATERIAL		APPROVALS	DATE	Electronic Theatre Controls, Inc. <small>1000 WEST BELTLINE HIGHWAY WILMINGTON, DE 19807</small> LIVE SHOW LIGHTING CONTROL SYSTEM CONTROL PANEL LAYOUT
FINISH		DRAWN	1-24-83	
NEXT ASSY		CHECKED	2/4/83	
USED ON		ISSUED		
APPLICATION		DO NOT SCALE DRAWING		SIZE FSCH NO D
				DWG NO LSLC-005
				SCALE FULL
				SHEET 1 of 1

8 7 6 5 4 3 2 1

DWG NO		SN	REV	1
REVISIONS				
ZONE	REV	DESCRIPTION	DATE	APPROVED

IF A DIMENSION IS NOT SPECIFIED, IT SHALL BE AS SHOWN. ALL DIMENSIONS ARE IN INCHES UNLESS OTHERWISE SPECIFIED. DIMENSIONS ARE TO FACE UNLESS OTHERWISE SPECIFIED. DIMENSIONS ARE TO CENTER UNLESS OTHERWISE SPECIFIED. DIMENSIONS ARE TO CENTER UNLESS OTHERWISE SPECIFIED. DIMENSIONS ARE TO CENTER UNLESS OTHERWISE SPECIFIED.

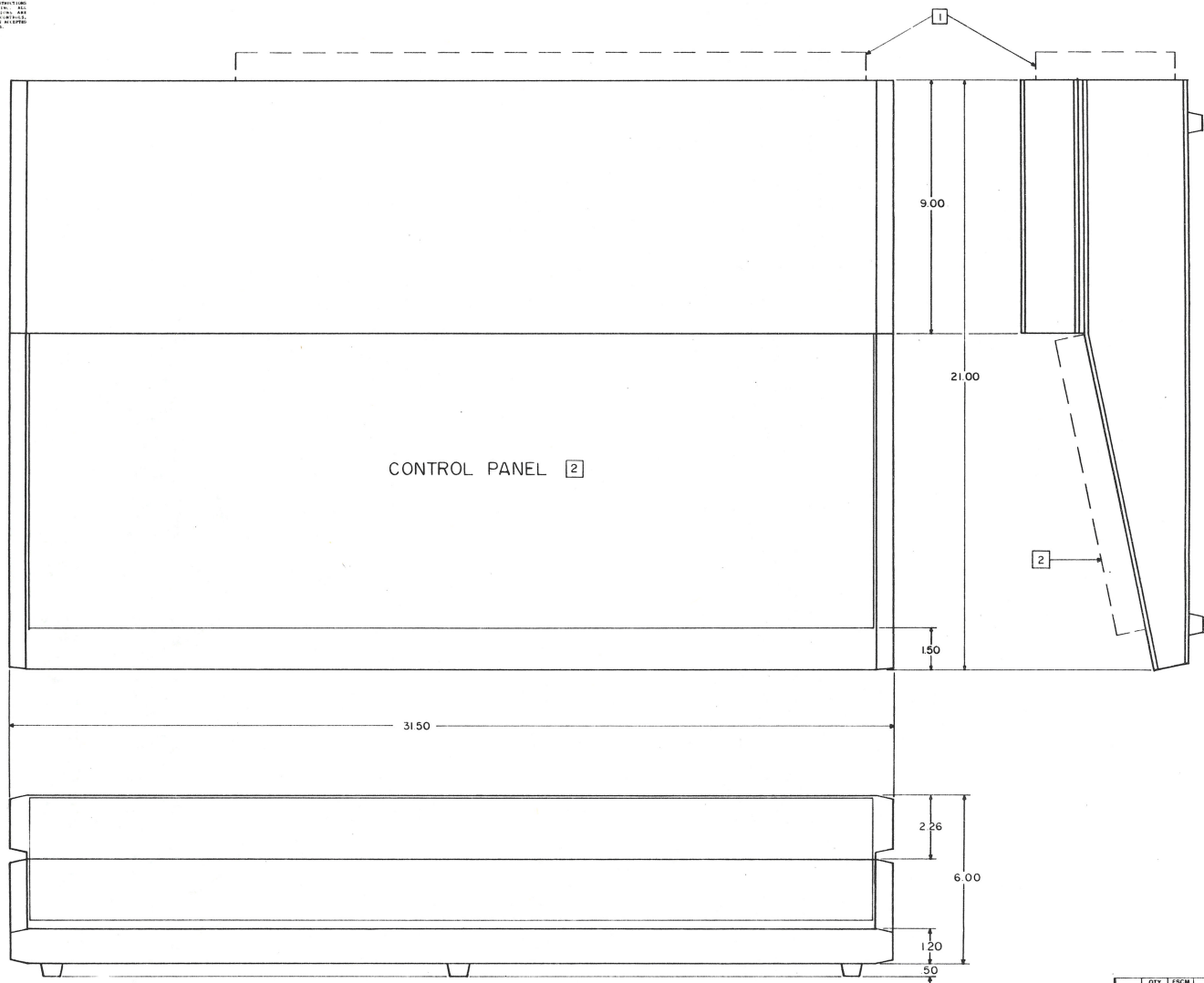

CONTROL PANEL 2

31.50

9.00

21.00

1.50

2.26

6.00

1.20

.50

- 2 DO NOT PUT PADDING ON PANEL AREA
 - 1 ALLOW SPACE FOR CONNECTORS
- NOTES

QTY	FSCM	PART OR IDENTIFYING NO	NOMENCLATURE OR DESCRIPTION	MATERIAL SPECIFICATION
PARTS LIST				
UNLESS OTHERWISE SPECIFIED DIMENSIONS ARE IN INCHES TOLERANCES ARE FRACTIONS DECIMALS ANGLES		CONTRACT NO		
XXX .020		APPROVALS DATE		
MATERIAL		DRAWN 5/13/82		
FINISH		CHECKED FFE 2/1/82		
ISSUED		SCALE 1/2		
NEXT ASSY	USED ON	APPLICATION DO NOT SCALE DRAWING		

ELECTRONIC THEATRE CONTROLS, INC. 3000 WEST BELLINGHUE HIGHWAY BELLINGHUE, WASH. 98003		LIVE SHOW LIGHTING CONTROL SYSTEM CONSOLE DIMENSIONS		DWG NO LSLC-010	
DATE 5/13/82		DRAWN 5/13/82		REV	
CHECKED FFE 2/1/82		ISSUED		SHEET 1 of 1	

THIS DOCUMENT IS THE CONFIDENTIAL PROPERTY OF ELECTRONIC THEATRE CONTROLS, INC. AND IS LOANED SUBJECT TO RETURN UPON DEMAND. TITLE TO THIS DOCUMENT IS TO BE USED ONLY IN ACCORDANCE WITH WRITTEN LICENSE OR WRITTEN INSTRUCTIONS OF ELECTRONIC THEATRE CONTROLS, INC. ALL RIGHTS TO DESIGN AND INVENTIONS ARE RESERVED BY ELECTRONIC THEATRE CONTROLS, INC. POSSESSION OF THIS DOCUMENT IS ACCEPTED SUBJECT TO THE FOLLOWING CONDITIONS.

REVISIONS				
ZONE	REV	DESCRIPTION	DATE	APPROVED

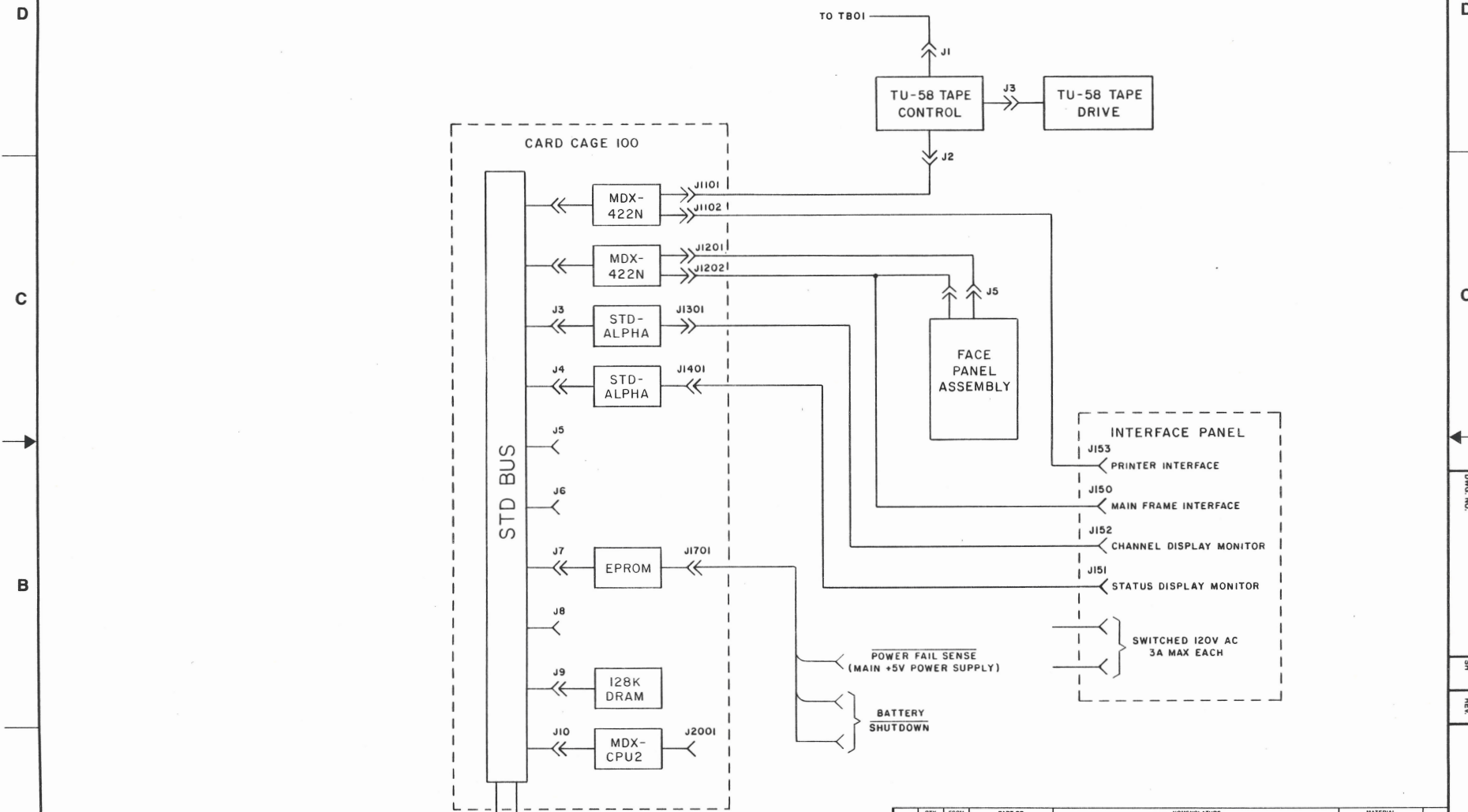

2. REFER TO DRAWING LSLC-012 FOR CONNECTOR SCHEDULES.
 1. REFER TO DRAWING LSLC-014 FOR POWER SUPPLY WIRING.

NOTES

QTY REQD	FSCM NO	PART OR IDENTIFYING NO	NOMENCLATURE OR DESCRIPTION	MATERIAL SPECIFICATION
PARTS LIST				
UNLESS OTHERWISE SPECIFIED DIMENSIONS ARE IN INCHES TOLERANCES ARE: FRACTIONS DECIMALS ANGLES XXX .XXX .		CONTRACT NO.		
MATERIAL		APPROVALS		DATE
FINISH		DRAWN <i>J. Gojmerac</i>		9-15-82
NEXT ASSY		CHECKED <i>FKF</i>		2/1/83
USED ON		ISSUED		
APPLICATION		DO NOT SCALE DRAWING		
		LIVE SHOW LIGHTING CONTROL SYSTEM		
		CONSOLE INTERCONNECTION DIAGRAM		
		SIZE C	FSCM NO.	DWG. NO. LSLC-009
		SCALE NONE	SHEET 1 of 1	

DWG. NO.		SH	REV	1
REVISIONS				
ZONE	REV	DESCRIPTION	DATE	APPROVED

THIS DRAWING IS THE SOLE PROPERTY OF ELECTRONIC THEATRE CONTROLS, INC. AND IS LOANED TO YOU BY THE COMPANY. IT IS TO BE USED ONLY FOR THE PURPOSES FOR WHICH IT WAS ISSUED. NO REPRODUCTION OR TRANSMISSION OF THIS DRAWING IN ANY FORM OR BY ANY MEANS, ELECTRONIC OR MECHANICAL, INCLUDING PHOTOCOPYING, RECORDING, OR BY ANY INFORMATION STORAGE AND RETRIEVAL SYSTEM, IS PERMITTED WITHOUT THE WRITTEN PERMISSION OF ELECTRONIC THEATRE CONTROLS, INC.

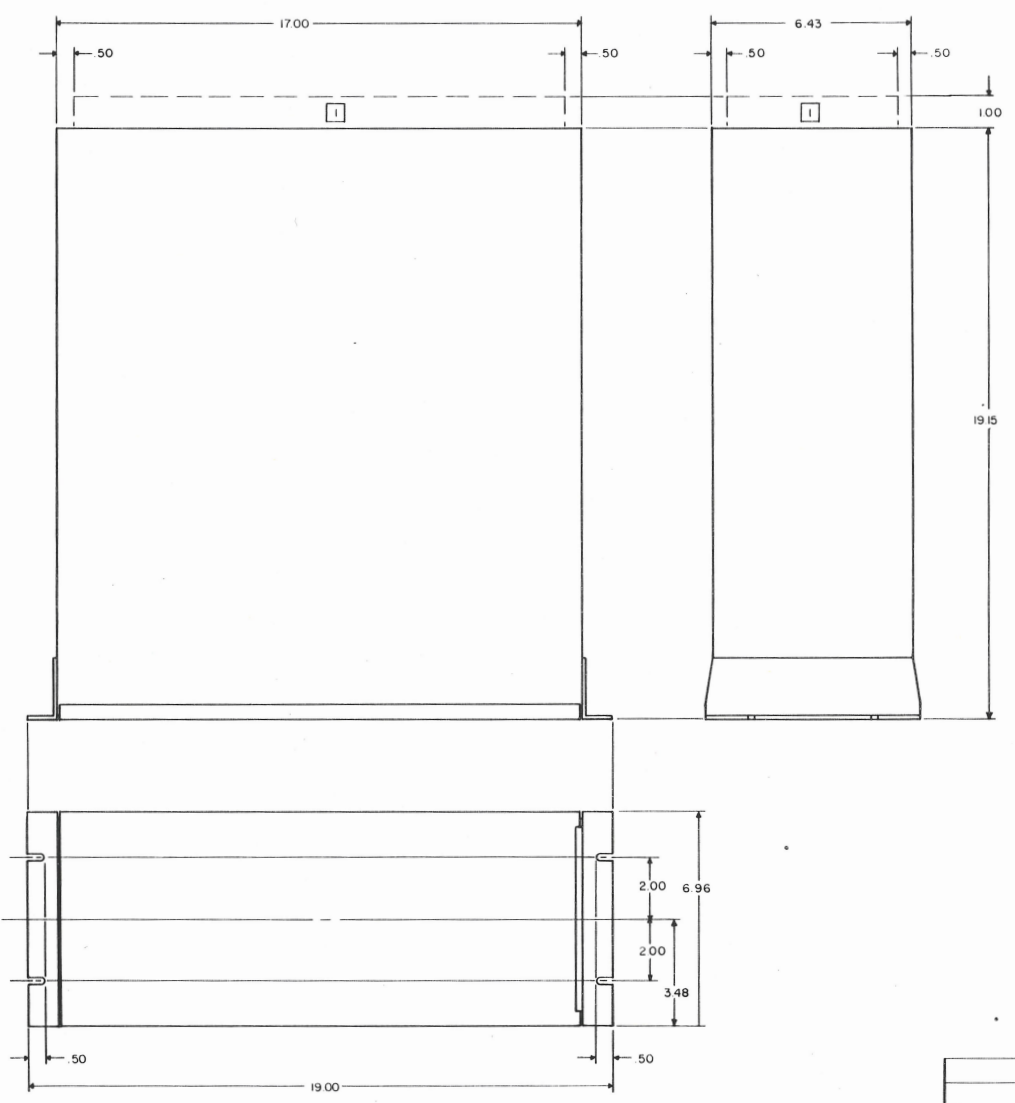

1 ALLOW SPACE FOR CONNECTORS

NOTES

QTY	FSCM NO.	PART OR IDENTIFYING NO.	NOMENCLATURE OR DESCRIPTION	MATERIAL SPECIFICATION
PARTS LIST				
UNLESS OTHERWISE SPECIFIED DIMENSIONS ARE IN INCHES TOLERANCES ARE FRACTIONS DECIMALS ANGLES XX.XX		CONTRACT NO.		
MATERIAL		APPROVALS	DATE	
FINISH		DRAWN <i>SPR</i>	5/12/82	
NEXT ASSY		CHECKED <i>FLF</i>	2/1/83	
USED ON		ISSUED		
APPLICATION		DO NOT SCALE DRAWING		
		Electronic Theatre Controls, Inc. 3000 WEST BELLINGHUE AVENUE MIDDLEBURY, VT 05751		
		LIVE SHOW LIGHTING CONTROL SYSTEM		
		MAIN FRAME DIMENSIONS		
SIZE	FSCM NO.	DWG. NO.	REV	
D		LSLC-050		
SCALE 1:2		SHEET 1 of 1		

REVISIONS				
ZONE	REV	DESCRIPTION	DATE	APPROVED

THIS DOCUMENT IS THE CONFIDENTIAL PROPERTY OF ELECTRONIC THEATRE CONTROLS, INC. AND IS LOANED SUBJECT TO RETURN UPON DEMAND. IT IS TO BE USED ONLY PURSUANT TO WRITTEN LICENSE OR WRITTEN INSTRUCTIONS OF ELECTRONIC THEATRE CONTROLS, INC. ALL RIGHTS TO PATENTS AND INVENTIONS ARE RESERVED BY ELECTRONIC THEATRE CONTROLS, INC. POSSESSION OF THE DOCUMENT IS ACCEPTED SUBJECT TO THE FOREGOING CONDITIONS.

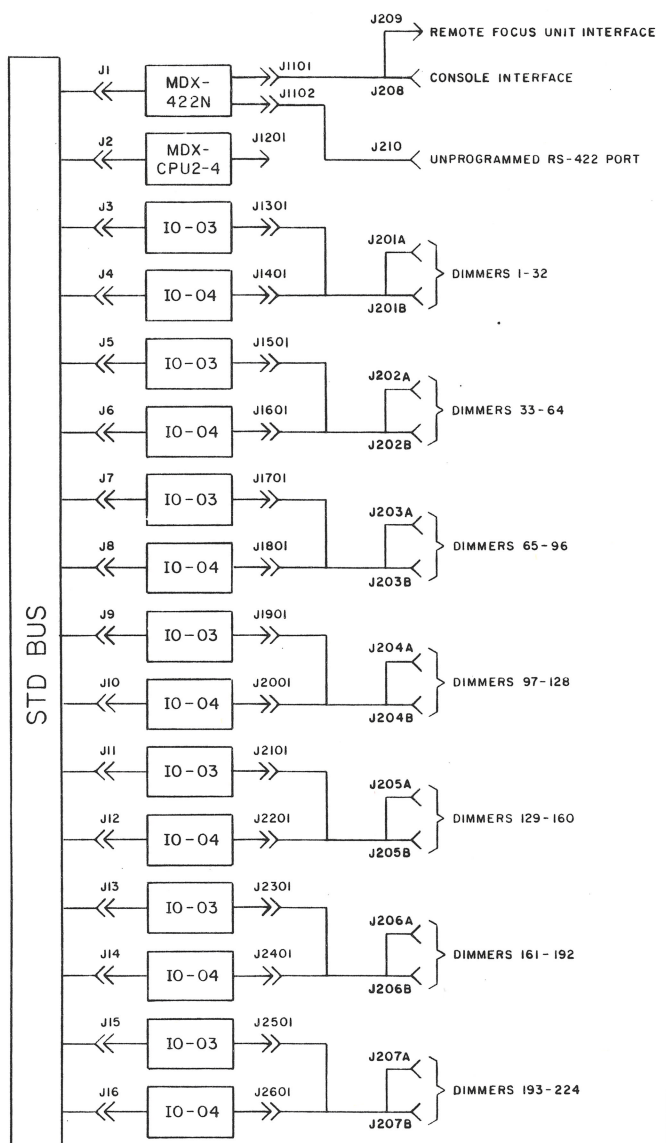

2. REFER TO DRAWING LSLC-052 FOR CONNECTOR SCHEDULES.
 1. REFER TO DRAWING LSLC-054 FOR POWER SUPPLY WIRING.

NOTES

QTY	FSCM	PART OR IDENTIFYING NO.	NOMENCLATURE OR DESCRIPTION	MATERIAL SPECIFICATION
PARTS LIST				
UNLESS OTHERWISE SPECIFIED DIMENSIONS ARE IN INCHES TOLERANCES ARE: FRACTIONS DECIMALS ANGLES XX .XXX			CONTRACT NO.	
MATERIAL		APPROVALS	DATE	Electronic Theatre Controls, Inc. 3002 WEST BELTLINE HIGHWAY MIDDLETON, WI 53562
FINISH		DRAWN J. Cojmerac	9-14-82	
NEXT ASSY		CHECKED ERF	2/1/83	
USED ON		ISSUED	SIZE C	FSCM NO.
APPLICATION		DO NOT SCALE DRAWING	DWG. NO. LSLC-049	REV.
			SCALE NONE	SHEET 1 of 1

D
C
B
A

D
C
B
A

4 3 2 1

4 3 2 1